

SMITH & NOBLE

Step by Step Installation Instructions

Fabric Shades

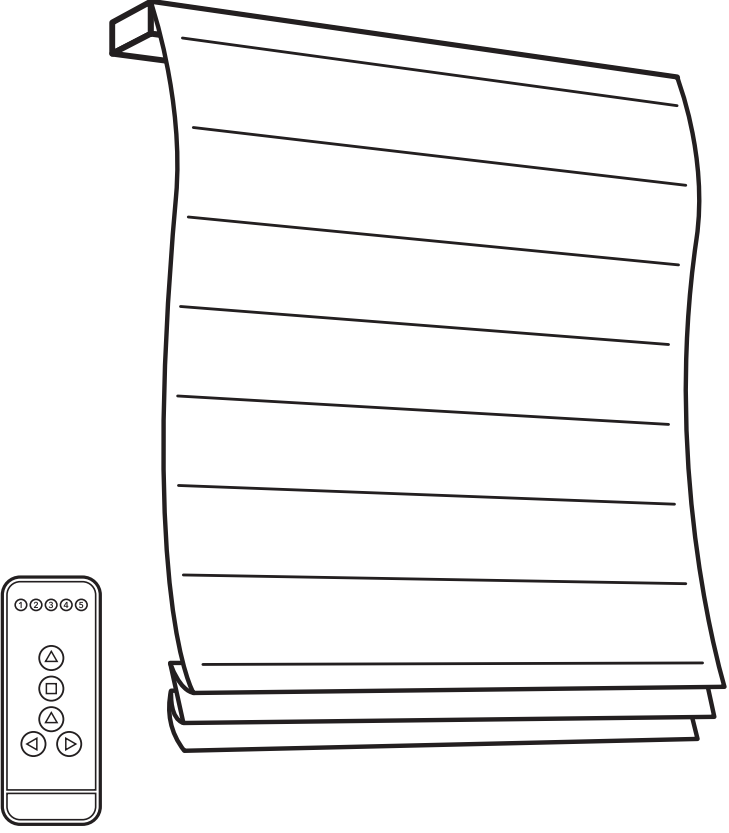

Motivia®
Motorization

Everything You Need

A Smooth Set-Up

We want you to love your new window coverings and that includes having a smooth installation experience. We recommend saving this guide. If you encounter any difficulties or questions, please reach out to us for help. It's why we're here. Call us at 800.248.8888 for more info on installation.

We recommend you hold on to all packaging until your window coverings are fully installed. Should something go wrong (we strongly doubt it), we want any potential returns to be a painless as possible.

Customer Service Hours

Monday – Friday: 6am – 6pm PT

Saturday – Sunday: 7am – 4pm PT

smithandnoble.com



Table of Contents

<i>Step 1</i> -	Getting Started	3
<i>Step 2</i> -	Mounting the Brackets.....	4
<i>Step 3</i> -	Operating the Remote Control.....	5 - 6
	Recharging your Shade	6
	Troubleshooting.....	Back Cover
	Care & Cleaning	Back Cover
	Safety	Back Cover
	Warranty.....	Back Cover

Step 1 – Getting Started

Getting Started

Before you begin, check the accompanying diagram to make sure you have all the parts you need.

TOOLS YOU WILL NEED TO INSTALL YOUR HARDWARE: Pencil, screwdriver, ¼" nut driver, level, and a drill with a ⅜" drill bit.

Note: It's important to monitor the amount of pressure you apply when using a drill. If the screws are too tight this may cause the screw itself to break off in the wall or window frame.

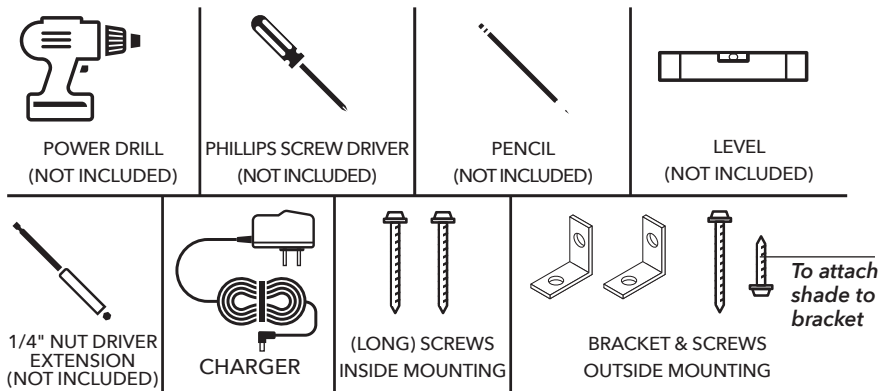

Inside mount shades will not have brackets.

You'll need to make sure the surface you intend to install your hardware is sturdy enough to accommodate the brackets. If you're screwing directly into a surface this means locating wood studs that are strong enough to securely bond with the included screws. Otherwise, you'll need to use a secure fastener (as illustrated) but please note this piece is not included.

When selecting a fastener be sure it's designed to support the weight of the product being installed (if you're not sure, either give us a call or ask a professional at your local hardware store). Once obtained, follow the fastener manufacturer's instructions regarding proper installation.

WALLBOARD OR PLASTER: Hollow wall applications: Use a secure fastener designed specifically for this purpose.

METAL: Prepare by pre-drilling holes and then using the included screws.

CONCRETE, STONE, BRICK OR TILE: Use a masonry drill and surface-specific plugs, anchors, or screws.



Step 2 – Mounting the Brackets

Inside Mount

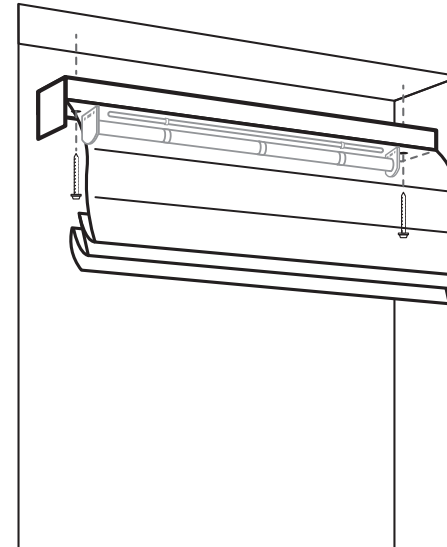

Hold the shade inside the window frame so that the front edge of the shade and the front edge of the window line up. Don't forget to keep it centered. It should be a tight fit not much space to move around. With the shade positioned exactly as you'd like it, press a screw through each of the riveted holes on the headrail. The screws' tips will leave small indentations in the window frame to help you keep track. Remove the shade and use a ⅜" drill bit to pre-drill the mounting holes. Then attach the shade with the long screws provided into the pre-drilled holes using the drill and ¼" nut driver or Phillips screwdriver.

Outside Mount

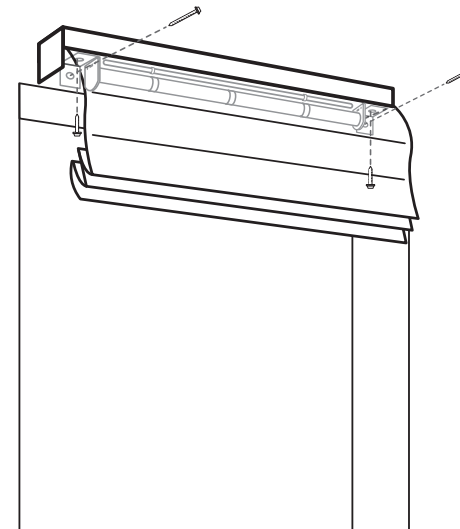

First, hold the shade above the window so that it's perfectly centered. Using a pencil, mark where the bottom of the headrail hits the window frame or wall and then place the provided brackets to window frame or wall, where they will be mounted. Mark one of the bracket holes with a pencil. (Some notes on accuracy: brackets should be level with one another, and ½" from the headrails edges.) Next, using the long screws provided, attach the brackets to the window frame or wall and place the headrail on top of the brackets. Then pierce the fabric and pre-drill the mounting holes using a ⅜" drill bit at each bracket location. Attach the shade to the brackets using the provided short screws, using the drill and ¼" nut driver or Phillips screwdriver.

Step 3 – Operating the Remote Controls

Remote Control

For added protection, your remote control arrived with a protective film on the top. Please remove this film prior to use. Select the desired channel with the CHANNEL key. The channel indicator light will illuminate the channel that is on. If all 5 lights are lit, the remote will control all 5 channels at once.

Tapping the UP or DOWN keys for less than 2 seconds will move the shade in short steps. Holding the UP or DOWN keys down for more than 2 seconds before releasing, will operate the shade in the faster standard speed.

Press the UP or DOWN keys to raise or lower the shade. Press the STOP key to stop the shade anywhere along the window.

Setting and Using a Favorite Position:

Use the UP or DOWN buttons to position the shade at the desired "favorite" position. First press and hold the LIMIT button on the back of the remote with a small screwdriver or tip of a pen. While holding the LIMIT button press and hold the UP button. Release both buttons when the shade jogs.

With the shade at either the upper or lower limit, simply press the STOP button to bring the shade to the "favorite" position. To go to the "favorite" position from any other location, make sure the shade has been stopped for at least three seconds before pressing the STOP button.

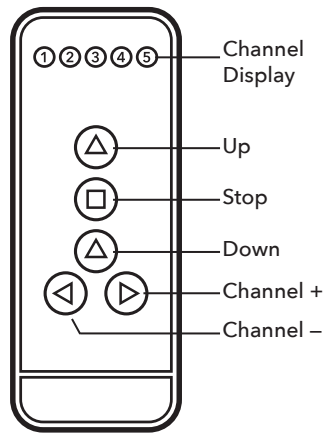
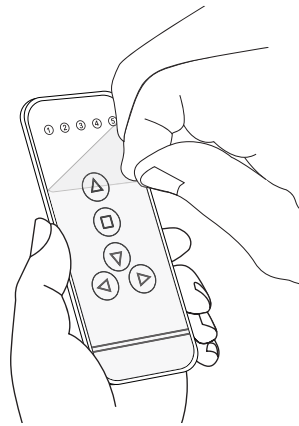

FRONT OF REMOTE

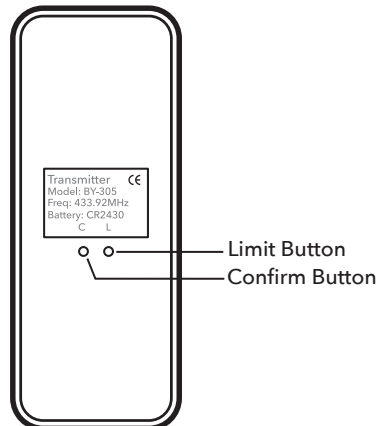

BACK OF REMOTE

Recharging the Shade

Recharging the Shade

When the shade begins to operate slower than normal it is time to charge the battery.

Plug the 8.4v charger into the port motor. Plug the charger into an electrical outlet.

A red light on the charger indicates that the battery is charging.

To fully charge the batteries, allow the batteries to charge for at least 1 hour after the light on the charger turns green.

A typical charge cycle can take between 4-6 hours.

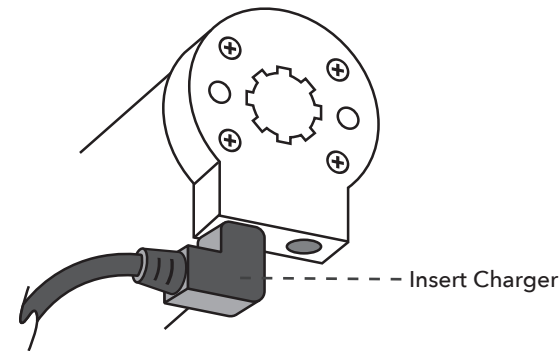
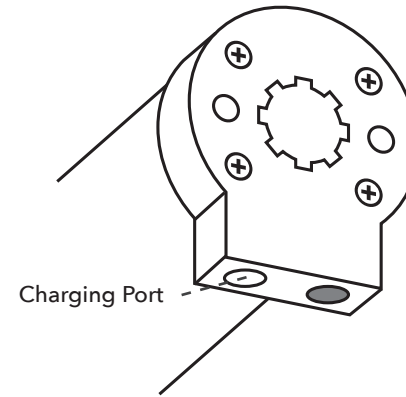

Dressing Your Shade

Dressing Your Shade

Once installed, you'll want your Smith & Noble shades to look as stylized as they do in our catalog; to "dress" your shade simply smooth folds as you raise the shade. Your shade will gradually develop a pleat/fold memory and minimal dressing will be needed.

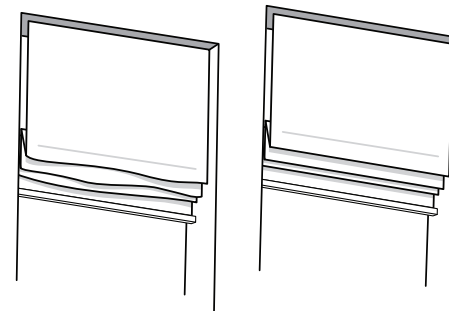

The shade does not work or runs slowly.	Recharge the motor.
The shade only goes in one direction (up or down).	The limit setting was unsuccessful and needs to be reset. Refer to the Motorization Guide.
The indicator light on the remote does not shine or the remote range becomes shorter.	Replace the battery in the remote (CR2430 Lithium).
The motor beeps when operated.	Recharge the motor.

If these suggestions don't work, then please give us a call or visit our website.

Care & Cleaning / Safety

Care & Cleaning

Occasional light vacuuming with a soft bristle attachment or gentle feather dusting is all that is required to keep your shades looking fresh and neat.

Safety First. Style Second To None™.

Great style should never come at the cost of safety. Every Smith & Noble window treatment conforms strictly to today's safety standards, including permanent tie-down devices and built-in cord stops. To protect young children and pets, there's no better way to eliminate risk than to use one of our Motivia™ motorized products.



Child Safety

Warranty Service

The enjoyment of your window covering should be everlasting, which is why our products come with a limited lifetime warranty. The warranty applies to the original owner, requires a proof of purchase (hang on to your receipt!) and covers defects in material or craftsmanship. Hardware must have been properly installed. We reserve the right to determine if your hardware warrants a repair or a replacement. Visit smithandnoble.com/guarantee to see full details. In need of warranty service? Call us at **800.248.8888** and we'll arrange for a repair or replacement ASAP.