

---

# Motivia® Motorization Programming Guide for Drapery Hardware

Operating & Programming  
Guide

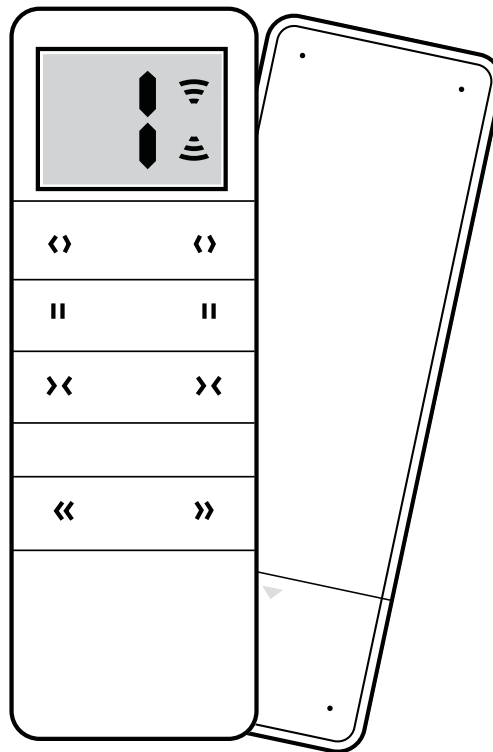

Drapery Hardware

---

# Table of Contents

OVERVIEW ..... 3

OPERATION ..... 4

SINGLE ROD SET - Pairing the Remote..... 5

DOUBLE ROD SET - Pairing the Remote..... 6

DOUBLE ROD SET - Setting the Limits ..... 7

SETTING FAVORITES..... 8

ADDING / REMOVING REMOTE..... 9

TROUBLESHOOTING ..... 10

## Customer Service Hours

Monday – Friday: 6am – 6pm PT  
 Saturday – Sunday: 7am – 4pm PT  
 smithandnoble.com



Your remote should come programmed to your rod set from the factory.

These directions are for programming a motor from a factory default state. If the hardware has been programmed and other adjustments need to be made, additional directions will be at the end of the document.

Please read entire document before programming.

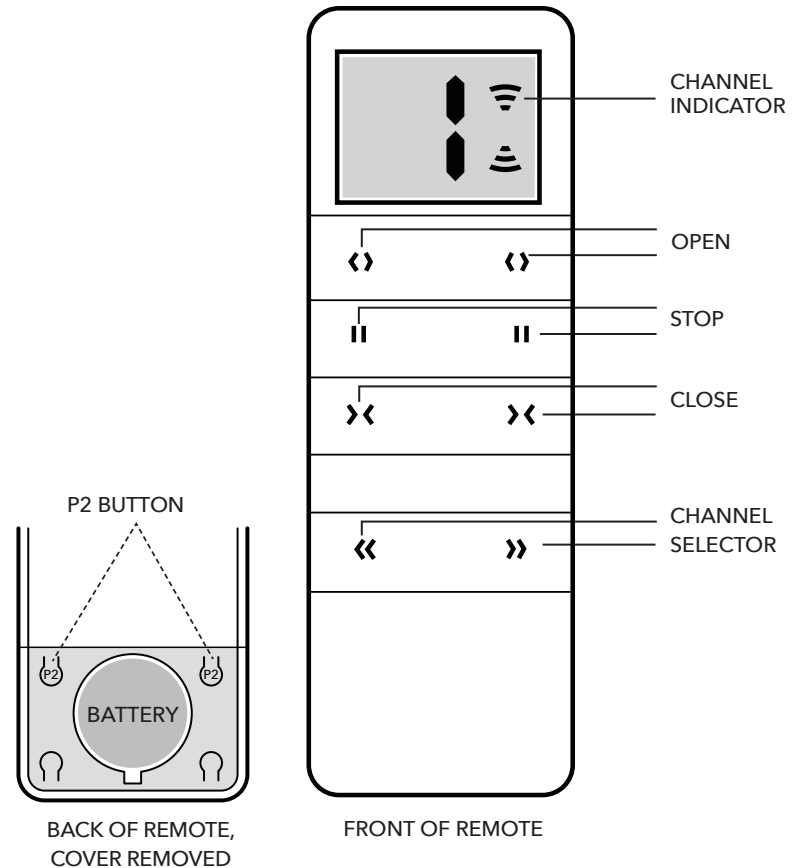

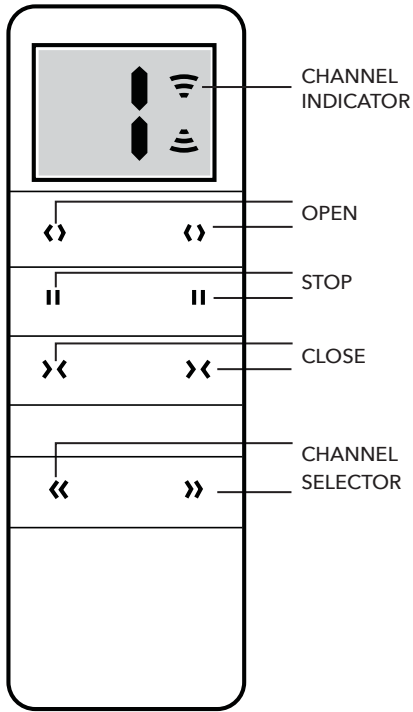

Front of Remote

### Operating the Remote

Select the desired channel with the CHANNEL buttons. The channel indicator will show the channel that is on. If it's on zero (0), the remote will control all rods programmed to that remote at once.

#### RAISE AND LOWER THE SHADE

1. Holding the UP or DOWN buttons for about 2 seconds will move the blind up or down.
2. Press the UP or DOWN buttons to raise or lower the blind.
3. Press the STOP button to stop the blind at any position.

#### OPEN AND CLOSE THE SLATS

1. Select a channel using the CHANNEL button. (Press right or left side of button to scroll through the channels.)
2. Tapping the UP or DOWN button for less than 2 seconds will move the slats in short steps. This allows precise control of the slat open/close position.

NOTE: Every operation below needs to be done within 4 seconds of each other.

### Single Rod Sets

#### Step 1 - Pair the Remote to Hardware

1. Remove cover from the back of the remote and locate the right P2 button.
2. Press << or >> until the desired channel is reached.
3. Detach the bottom cover of the motor by snapping it off.
4. Using a pencil, press the Motor Setting Button on the motor until indicator light flashes once. Do not hold longer.
5. Press right P2 button twice, the indicator light on the motor should flash repeatedly.

The remote will now work with the hardware.

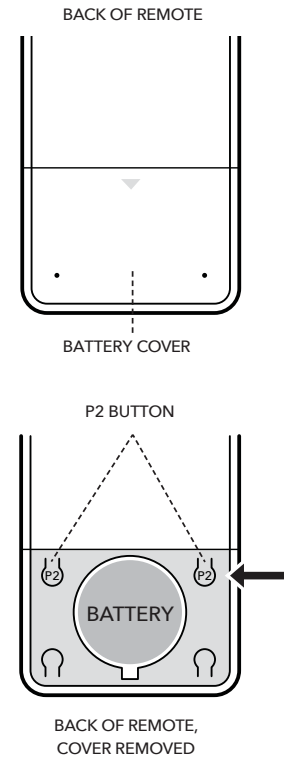

#### Step 2 - Setting Limits

1. Press left Close Button (> <) and allow carriers to close all the way.
2. Press left Open Button (< >) and allow carriers to open all the way. Memorized limit position is now set.

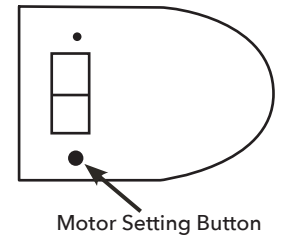

NOTE: Every operation below needs to be done within 4 seconds of each other.

## Double Rod Sets

### Step 1 - Pair the Remote to Hardware

1. To program the front rod, remove cover from the back of the remote and locate the right P2 button.
2. Press << or >> until the desired channel is reached.
3. Detach the bottom cover of the motor by snapping it off.
4. Using a pencil, press the Motor Setting Button on the motor until indicator light flashes once. Do not hold longer.
5. Press right P2 button twice, the indicator light on the motor should flash repeatedly.
6. To program back rod, locate the left P2 button.
7. Press << or >> until the desired channel is reached.
8. Using a pencil, press the Motor Setting Button on the motor until indicator light flashes once. Do not hold longer.
9. Press left P2 button twice, the indicator light on the motor should flash repeatedly.

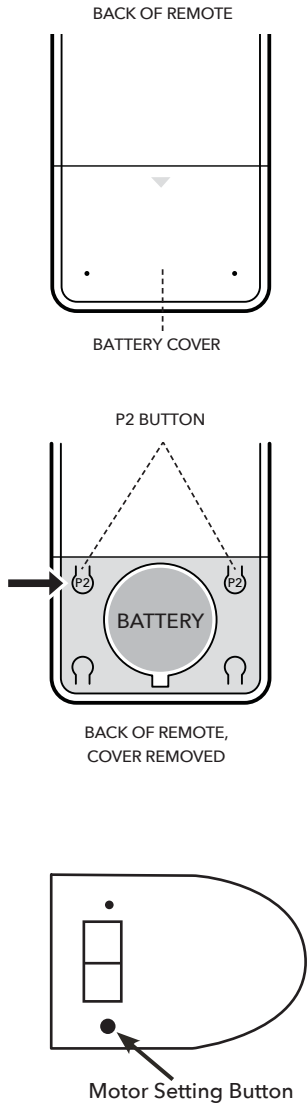

NOTE: Every operation below needs to be done within 4 seconds of each other.

### Step 2 - Setting Limits

1. Press left Close Button (> <) and allow carriers to close all the way.
2. Press left Open Button (< >) and allow carriers to open all the way. Memorized limit position is now set.

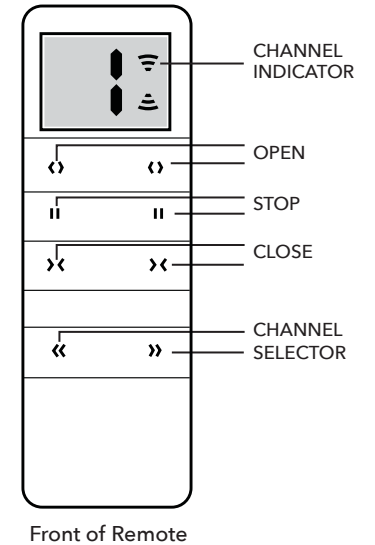

## Setting & Using A Favorites Position

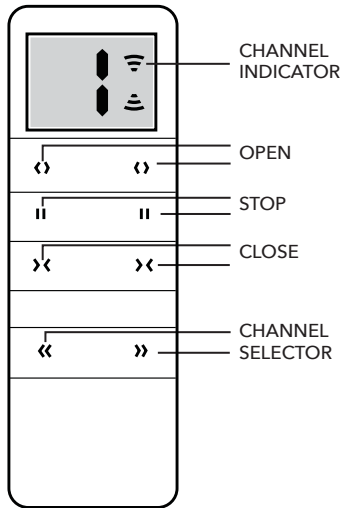

Front of Remote

1. Stop curtain at the desired Favorites Position using the Stop Button on the remote.
2. Remove back cover of remote.
3. Press P2 button on the remote for 2 seconds
4. Press Stop Button twice on the remote firmly for a second each.
5. Open or Close the draperies.
6. To activate 3<sup>rd</sup> Limit, press stop button firmly for approximately 2 seconds. Favorites Position is now set.

## Removing 3rd Limit Favorites Position

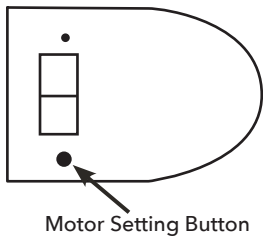

1. Press and hold Stop Button for about 5 seconds. Curtain will move to Favorites Position.
2. Press P2 Button on the remote for 2 seconds.
  - If you are removing favorites position for left control press the P2 Button on the Right of the back side.
  - To remove from the right control, press P2 Button on the Left of the back side.
3. Press Stop Button twice on the remote. 3rd Limit is now removed.

## Adding a Remote

Repeat STEP 1 - "PAIR" the Remote to the Hardware.

## Removing a Remote

Press and hold the Motor Setting Button for 10 seconds until LED indicator light flashes 5 times.

Note: Motor is now reset to factory default settings and all remotes paired to the motor will need to be reprogrammed.

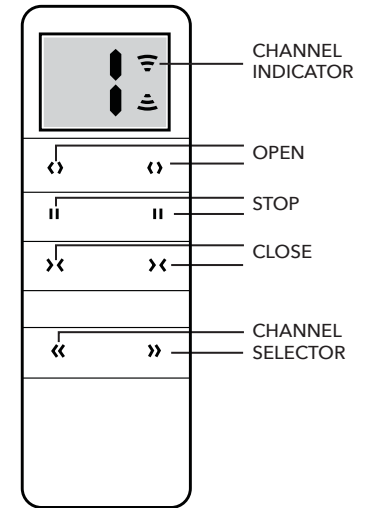

Front of Remote

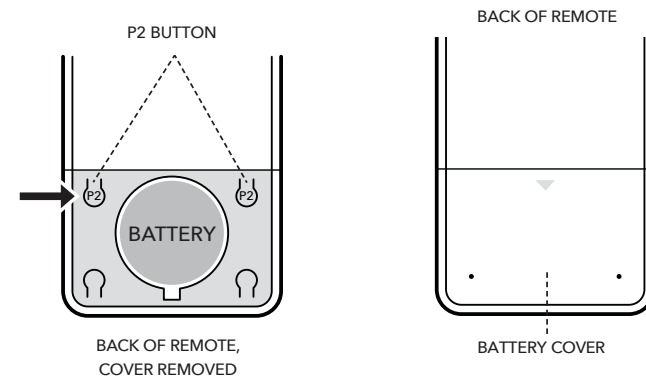

## TROUBLESHOOTING

PROBLEM	SOLUTION
Rod set will not operate	<ol style="list-style-type: none"> <li>1) Make sure that the motor is plugged in and there is power to the outlet.</li> <li>2) Make sure the battery in the remote has the positive (+) symbol facing up. Replace the battery if necessary.</li> <li>3) If above items are all good, then reboot and relink your rod.               <ol style="list-style-type: none"> <li>a. Connect motor to its power source.</li> <li>b. Locate the Motor Setting Button.</li> <li>c. Using a pencil press Motor Setting Button for 10 seconds or until the indicator light flashes.</li> <li>d. Motor is now reset to factory settings.</li> <li>d. Pair the remote to the hardware.</li> </ol> </li> </ol>
Master carriers will not open or close all the way.	<ol style="list-style-type: none"> <li>1) Cancel the limit position               <ol style="list-style-type: none"> <li>a. Press Right P2 Button, indicator light flashes once.</li> <li>b. Press Left Close Button, indicator light flashes once.</li> <li>c. Press Right P2 Button, indicator light flashes 5 times.</li> <li>d. Limit position has been cancelled.</li> </ol> </li> </ol>
Rod set opens when pressing close button on the remote	<ol style="list-style-type: none"> <li>1) Hold the Motor Setting Button for 4 seconds or until the indicator light flashes once then once again. Release the button after the second flash.</li> <li>2) Press the Left Close Button on the remote. Indicator light should flash 5 times.</li> <li>3) Reverse of direction setting is now complete.</li> </ol>
I have reset the motor to factory settings and rod set still will not operate.	<ol style="list-style-type: none"> <li>1) Follow STEP 1 in the Programming Guide and pair the remote to the hardware.</li> </ol>

For more trouble shooting help, call us at 800.248.8888  
 or visit us online at [smithandnoble.com](http://smithandnoble.com) to connect with a live chat assistant  
 6am - 6pm Monday - Friday PT, 7am-4pm Saturday & Sunday PT

